

## IRB series 12" LED Inset Lights

- IRB/IN Inset Runway Edge
- IRB/IN-C Inset Runway Edge With Circling Guidance

### COMPLIANCE

- ICAO • Annex 14 Volume I
- EASA • CS-ADR-DSN
- IEC • TS 61827
- FAA • AC 150/5345-46
- EB No. 67
- NATO • STANAG 3316
- AENA • DIN/DSEYN/PPT/011
- Canada • TP 312
- Australia • MOS 139
- CAAC • AC-137-CA-2015-01-R1
- AC-137-CA-2015-03-R1

### FEATURES

- Prism windows protected from external forces by special mechanical design
- Low protrusion of 6 mm above ground level
- Applicable to all kinds of CCRs and ILCMS systems
- PWM digital regulation providing excellent consistency of chromaticity
- Integrated optical module with high light efficacy and good consistency
- Aluminum alloy forged top cover with hardened surface and corrosion resistance treatment
- Built-in surge protection
- Specially designed fail open system suitable for strong magnetism, vibration and other environments

### TECHNICAL DATA



#### MECHANICAL

Mounting • 6 x M10 bolts      Static Load Resistance •  $\geq 35t$       Dynamic Load Resistance • 40J      Net Weight • 6.9kg  
 Gross Weight • 7.2kg      Packing Dimensions • 354mm (L) x 324mm (W) x 135mm (H)



#### ENVIRONMENTAL

Operating Temperature •  $-55^{\circ}\text{C} \sim +55^{\circ}\text{C}$       Storage Temperature •  $-55^{\circ}\text{C} \sim +85^{\circ}\text{C}$       Protection Class • IP68      Humidity • 0~100%



#### ELECTRICAL

Connection • FAA L-823      Rated Input Current • 6.6A      Power Factor •  $>0.98$   
 Emission • IEC 61000-6-4      Immunity • IEC 61000-6-2      LED Lamp Life • Over 100,000 hours in typical operating conditions  
 Inset Runway Edge – White/White and White/Yellow • 42VA, White/Red • 30VA, Yellow/Red • 31.5VA, Red • 11VA, Yellow • 23VA, White • 24VA  
 Inset Runway Edge With Circling Guidance – White/White • 67VA, White/Yellow • 57VA, White/Red • 48VA, Yellow/Red • 42VA

## COMPONENTS

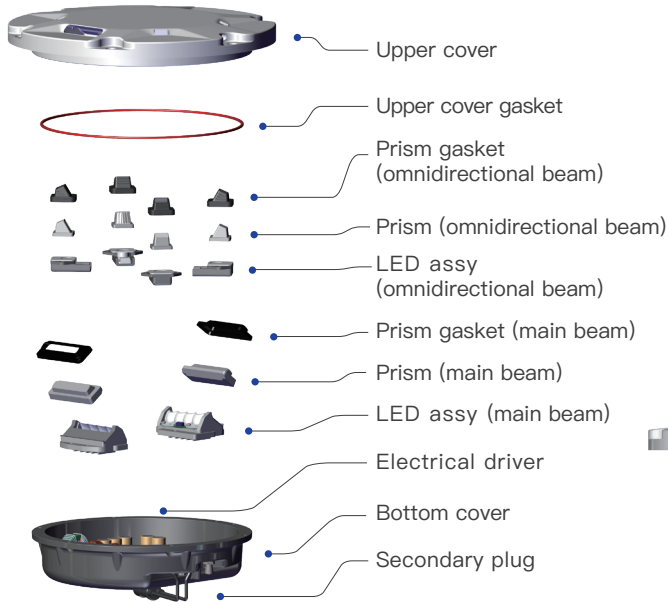

## DIMENSIONS

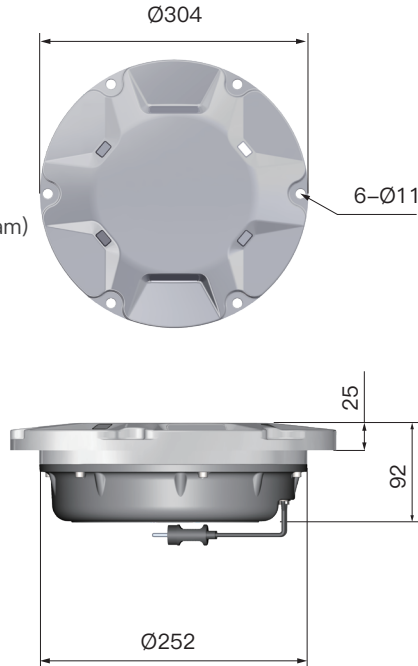

## ACCESSORIES

- © 12 inches shallow base assy (bottom entry/side entry)
- © 12 inches deep base assy
- © L-823 receptacle
- © 12 inches light fixture handle

## PHOTOMETRICS

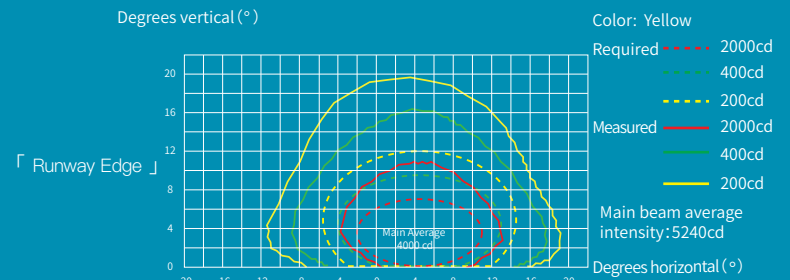
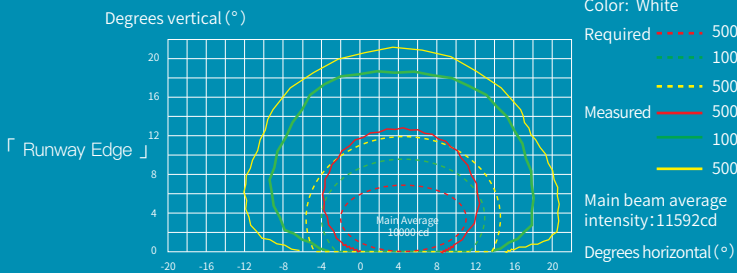

## ORDERING CODES

